



Azores 100 2U Solid State Storage

AZORES™ 100 2U SOLID STATE

NETHRA® Storage Overview

Nethra Imaging has been developing scalable image processing solutions for video and multimedia applications from inception. As sensor resolutions and frame rates have escalated, so has the data output from sensors. Building storage solutions for these applications requires specialized knowledge of imaging, video, storage and networking – brought together at Nethra for our customers benefit.

Nethra has released a line of high performance storage appliances – the Azores 100 platform - focused on the image and video processing markets in particular, with a focus on HD and UHD resolutions. These storage appliances have key features that differentiate them, and enable them to be deployed in both direct attached and networked environments quickly and economically.

Azores 100 Key Benefits

- Low Host CPU Overhead
- Minimal OS Impact
- Low Latency
- Low Power
- Consolidate Networks onto Layer 2 Ethernet
- Scalable Bandwidth & Capacity
- Scale to Ethernet Roadmap
- Simple Installation

Availability

The Azores 100 platform is sold and supported through OEM and System Integration partners only. It is not available for sale directly to end-users.

Technology Background

The Azores 100 platform is composed of 3 fundamental blocks; the transport interface, the storage interface and the actual media. In particular, the implementation of the transport block uses advanced fabric and tunneling technologies – ExpEther™ - developed in cooperation with NEC Research Laboratories, Japan.

The Host processor requires a Nethra FastPipe adapter card, plugged into the Host PCI Express fabric. Twin 10 Gbps fibers are used to either connect directly to the remotely located Azores 100 box, or to do so via a Layer 2 Ethernet switch. No drivers are needed for this adapter card – all communication is run at fiber-speed, in hardware.

However, the host processor does need to run the driver of the storage controller embedded in the Azores 100 box. This architecture results in a number of end-user benefits.

Low Host CPU Overhead

The use of ExpEther for transport means that all the communications are handled in hardware, transparently to the Host OS and application layer. There is no iSCSI or TCP/IP stack to run. The only drivers needed for the 100 series are the drivers needed for the storage controller located in the Azores 100 box. These drivers are standard drivers from established vendors.

This results in Host CPU overheads for remote storage that are similar to locally implemented solutions – a key breakthrough for practical use for remotely located storage, connected as though local to the PCI express fabric. The only requirement for effective use is that the host CPU provide high data throughput. Our testing has shown that a quad core Intel/AMD processor at 2.5 GHz or above has been found to be minimally acceptable.

Minimal OS Impact

No changes or modifications to the operating system are needed to implement the ExpEther interface. Testing on different versions of Linux and Windows has shown the maximum benefit when run on 64-bit versions.

Low Latency

The ExpEther interface adds less than 400 nanoseconds of delay per adapter, with 2 adapters needed to provide connection. Ethernet switches will add their delay; however good switches normally have delays in the 200 ~ 400 nanoseconds category as well.

Scalability – Bandwidth and Capacity

Working with video requires systems that can move large amounts of data with large files, quickly and economically. The Azores systems are designed to move data at the maximum capacity of the underlying technology – the integrated RAID controller operates at it's maximum transfer rates, with the FastPipe adapters maintaining sufficient headroom to ensure minimal transfer delays.

The Azores 100 series are being launched with bandwidths of 1.6 Gigabytes per second and 3.2 GigaBytes per second, depending on configuration. This bandwidth will continue to increase. The bandwidth into a given host processor will depend on the number of FastPipe adapter boards installed; each board currently gives about 2 GigaBytes per second of bandwidth, with negligible CPU loading. To increase the bandwidth for the host processor, multiple FastPipe adapter boards can be installed.

The initial capacity of the Azores 100 comes in two configurations – 1.5TB and 6TB. Scaling capacity can be achieved by connecting multiple storage boxes with an Ethernet switch, which is then connected to the host processor.

Please check with a Nethra representative for the latest performance numbers and their units.

Azores 100 Specifications

- 2U high
- Configurations: 1.5TB or 6TB
- Bandwidths: 1.6 GBps Read or 3.2 GBps Read
- Built-in link failover and multipathing
- Scalable by number of FastPipe adapter cards
- Each FastPipe adapter card: 2 GBps
- PCI-Express to 10 Gbps Ethernet tunneling

Usage Models

Existing FC SAN and TCP/IP NAS network storage structures can be scaled up with simple installation of the Azores 100 as illustrated.

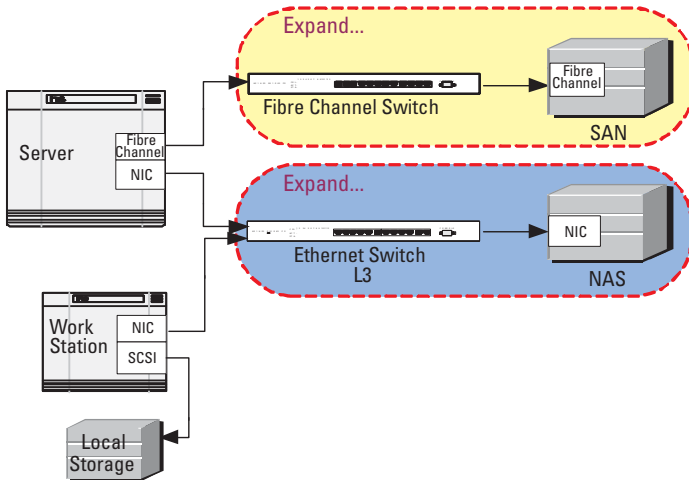

Figure 1. Typical FC SAN and TCP/IP NAS

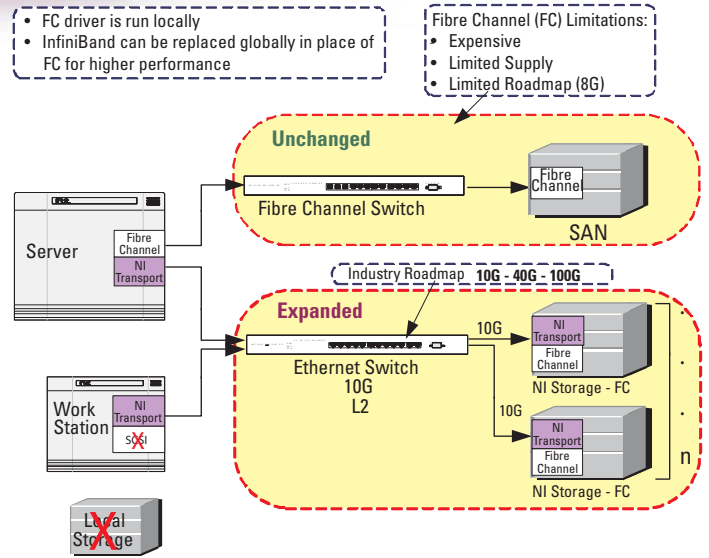

Figure 2. FC SAN Expanded

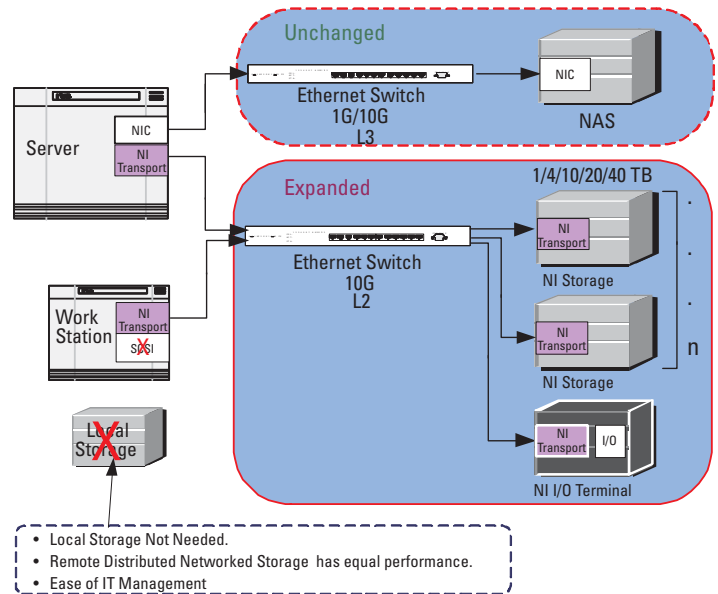

Figure 3. TCP/IP NAS Expanded

CORPORATE

Nethra Imaging, Inc.
2855 Bowers Ave.
Santa Clara, CA 95051
Voice: +1 (408) 200-1770
Fax: +1 (408) 855-8601
Email: sales@nethra.us.com

TAIWAN

Nethra Imaging, Inc.
4F.-5, No.146, Sec. 6, Mincyuan E. Rd.
Neihu District, Taipei City 11466,
Taiwan (R.O.C.)
Voice: +886-9-33709088
Email: ywang@nethra.us.com

JAPAN

Nethra Imaging, Inc.
2-33-4-101, Hagoromo-cho
Tachikawa-shi, Tokyo 190-0021
Voice: +81-90-1709-7607
Email: smatsuda@nethra.us.com